

Specifications for Approval

Customer : _____

Model name : LMC1623A-YTDDYN-B0 REV:A

Description : LIQUID CRYSRAL DISPLAY MODULE

DESIGN	CHECK	APPROVED

<p>Customer Approval</p>	<div style="margin-bottom: 10px;"> <input type="checkbox"/> Accept </div> <div style="margin-bottom: 10px;"> <input type="checkbox"/> Reject </div> <p>Comment:</p> <p style="text-align: right;">Approved by:</p>
---------------------------------	---



CONTENTS

※ LCD MODULE NUMBERING SYSTEM	1
1. FEATURES	2
2. MECHANICAL SPECIFICATIONS	2
3. ELECTRICAL SPECIFICATIONS	2
4. BLOCK DIAGRAM AND POWER SUPPLY	4
5. ELECTRO-OPTICAL CHARACTERISTICS	5
6. TERMINAL FUNCTIONS	6
7. TIMING CHARACTERISTICS	7
8. INSTRUCTION SET	9
9. FONT TABLE	12
10. QUALITY SPECIFICATIONS	13
11. RELIABILITY	18
12. HANDLING PRECAUTIONS	19
13. OUTLINE DIMENSION	21
※ 1. SAMPLES OUTGOING INSPECTION REPORT	
2. REVISION RECORD	

LCM MODULE NUMBERING SYSTEM

PART NUMBER: LMax.....yB-CDEFGHI-JK

L: LONDA TECHNOLOGY

M: MODULE

A: DISPLAY CONTENTS

C--- CHARACTER TYPE

G--- GRAPHIC TYPE

S---SEGMENT TYPE

x.....: CHARACTERS Vs. LINES FOR CM

COLUMNS Vs. ROWS FOR GM

SERIALS NUMBER FOR SM

y: DISTRIBUTE ACCORDING TO SIZE

B : VERSION OF PCB

C: LCD TYPE:

Y---YELLOW STN

G---GRAY STN

B---BLUE STN

F---FSTN

T---TN

D: POLARIZER TYPE:

R--- REFLECTIVE T--- TRANSFLECTIVE

M--- TRANSMISSIVE

E: VIEWING TEMPRETURE:

U--- 12:00

D--- 6:00

L--- 9:00

R--- 3:00

F: BACKLIGHT TYPE:

D---BOTTOM LED

S---SIDE LED

E--- EL

C--- CCFL

N---NO BACKLIGHT

G: COLOR OF BACKLIGHT :

Y---YELLOW/GREEN

G--- GREEN

B--- BLUE

W--- WHITE

O--- ORANGE

A--- AMBER

H:OPERATING TEMPRETURE:

N--- NORMAL, W--- EXTENDED , X:ESPECIALLY EXTENDED

I: DENOTE DIFFERENT CHARACTER TABLE:

NORMAL ELLIPSIS, T--- TAB , G--- COG

-JK:

FOR CM:

J: IC TYPE: A--- KS0066U

B--- SPLC780

K: CHARACTER STOREROOM SEQUENCE NUMBER

FOR GM:

J: BACKLIGHT DRIVER

Y--- WITH

N--- WITHOUT

K: DC-DC CONVERTER

Y--- WITH

N--- WITHOUT

MODEL

LMC1623A-YTDDYN-B0

1/21

PRODUCT SPECIFICATIONS

REV:A

1. FEATURES

The features of LCD are as follows

- * Display mode : STN, Positive, Transflective
- * Color : Display dot : Dark Blue
Background: Yellow / Green
- * Display Format : 16 X 2 Characters
- * IC : Samsung S6A0069 and S6A0065
- * Interface Input Data : 4-bit or 8-bit Parallel
- * Driving Method : 1/16 Duty, 1/4 Bias
- * Viewing Direction : 6 O'clock
- * Backlight : LED (Yellow-Green)

2. MECHANICAL SPECIFICATIONS

Item	Specification	Unit
Module Size	80(W) x 36(H) X 14.0MAX(T)	mm
Viewing Area	64.5(W) X 14(H)	mm
Effective Display Area	57.70(W)X 9.40(H)	mm
Character Font	5 X 8 with Cursor	
Character Pitch	3.65(W) X 5.05(H)	mm
Character Size	2.95(W) X 4.35(H)	mm
Dot Pitch	0.60(W) X 0.55(H)	mm
Dot Size	0.55(W) X 0.50(H)	mm

3. ELECTRICAL SPECIFICATIONS

3-1. Absolute Maximum Ratings (V_{SS}=0V)

Item	Symbol	Standard Value			Unit
		Min.	Typ.	Max.	
Supply Voltage For Logic	V _{DD} -V _{SS}	-0	-	+7.1	V
Supply Voltage For LCD Drive	V _{DD} -V ₀	-0	-	+10	V
Input Voltage	V _{IN}	V _{SS}	-	V _{DD}	V
Operating Temp.	T _{OP}	0	-	+50	°C
Storage Temp.	T _{ST}	-20	-	+70	°C

Notes : Voltages V_{DD}≥V₁≥V₂≥V₃≥V₄≥V₅≥V₀ must always be satisfied.

MODEL

LMC1623A-YTDDYN-B0

2/21

PRODUCT SPECIFICATIONS

REV:A

3. ELECTRICAL SPECIFICATIONS (Continued)

3-2. Electrical Characteristics (V_{SS}=0V)

Item	Symbol	Test Condition	Min.	Typ.	Max.	Unit
Logic Supply Voltage	V _{DD} – V _{SS}	Ta=0~50°C	4.5	5	5.5	V
LCD Drive Voltage (Recommended Voltage)	V _{DD} – V ₀	Ta=25°C	3.9	4.5	4.9	V
Input Voltage	“H” Level	V _{DD} =5V ± 5%	0.8	-	V _{DD}	V
	“L” Level		V _{IL}	0	-	0.2
Output Voltage	“H” Level	V _{DD} =5V ± 5%	0.8	-	V _{DD}	V
	“L” Level		V _{OL}	0	-	0.2
Current Consumption	I _{DD}	V _{DD} =5V ± 5% V _{DD} -V ₀ =4.5V	-	1.34	3.0	mA

NOTE: 1) Duty Ratio=1/16, Bias Ratio=1/4

2) Measuring in Dots ON-state

3-3. BACKLIGHT

3-3-1. Absolute Maximum Ratings

Item	Symbol	Condition	Min.	Typ.	Max	Unit
Forward Current	IF	Ta= 25°C	-	-	100	mA
Reverse Voltage	VR		-	-	5	V
Power Dissipation	PD	Ta= 25°C	-	-	500	mW

3-3-2. Opto-electronic Characteristics

Item	Symbol	Condition	Min.	Typ.	Max	Unit
Forward Voltage	VF	Ta= 25°C	-	4.2	4.5	V
Luminous	-	IF= 100mA	100	-	-	cd/m ²

MODEL

LMC1623A-YTDDYN-B0

3/21

PRODUCT SPECIFICATIONS

REV:A

4. BLOCK DIAGRAM AND POWER SUPPLY

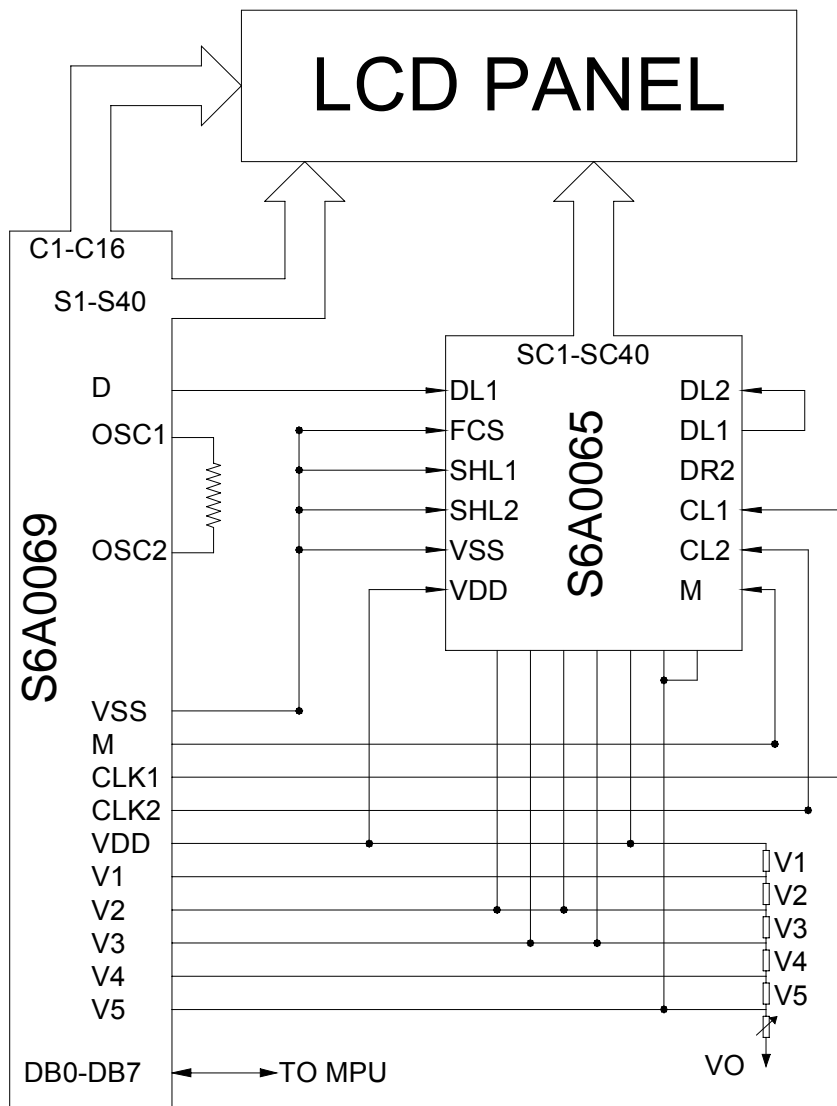

5. ELECTRO – OPTICAL CHARACTERISTICS

Item	Symbol	Temp.	Min.	Typ.	Max.	Unit	Conditions	Note
Viewing Angle	$\theta_2 - \theta_1$	25°C	30	92	-	Deg.	-	1,2
	Φ		80	90	-			
Contrast Ratio	Cr	25°C	2	11.1	11.9	-	$\theta = 0^\circ$ $\Phi = 0^\circ$	3
Response Time(rise)	Tr	25°C	-	92	250	ms	$\theta = 0^\circ$ $\Phi = 0^\circ$	4
		0°C	-	950	1150			
Response Time(fall)	Tf	25°C	-	119	250	ms	$\theta = 0^\circ$ $\Phi = 0^\circ$	4
		0°C	-	950	1150			

Note1 . Definition of Angle θ & Φ

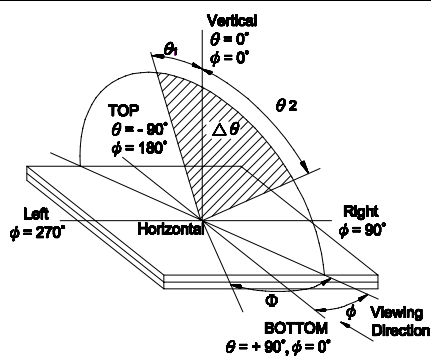

Note2. Definition of Viewing Angle θ_1 & θ_2

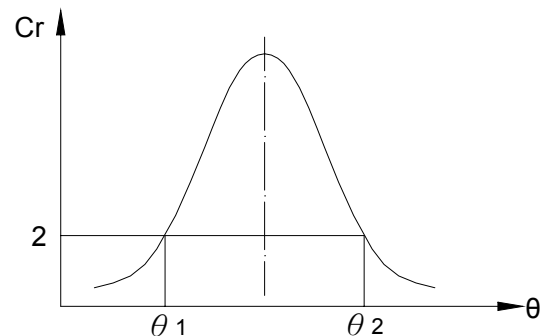

Note3 . Definition of Contrast Cr

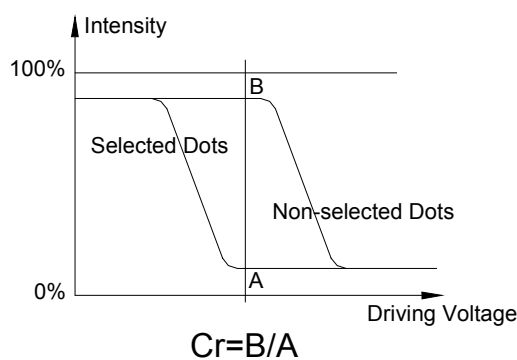

Note4. Definition of Optical Response

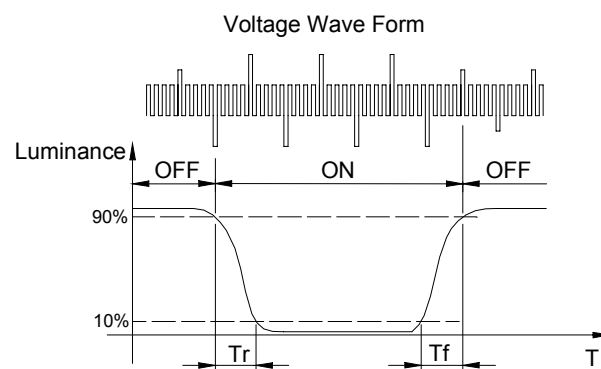

MODEL

LMC1623A-YTDDYN-B0

5/21

PRODUCT SPECIFICATIONS

REV:A

6. TERMINAL PIN FUNCTION

6-1. Interface Pin Function Description

Pin NO.	Symbol	I / O	Functions
1	V _{SS}	Power	GND
2	V _{DD}	Power	Power supply for logic circuit
3	V ₀	Power	Contrast adjustment
4	RS	I	Register select signal
5	R/W	I	Used as read/write selection input when Rw="high" read operation Rw="Low", write operation
6	E	I	Enable signal
7	DB0	I/O	Data bus
8	DB1		
9	DB2		
10	DB3		
11	DB4		
12	DB5		
13	DB6		
14	DB7		
15	A	-	BACKLIGHT(+)
16	K	-	BACKLIGHT(-)

7.TIMING CHARACTERISTICS

7-1. Write Mode (Writing data from MPU to LCM)

Mode	Symbol	Min.	Typ.	Max.	Unit
E Cycle Time	t_c	500	-	-	ns
E Rise / Fall Time	t_r, t_f	-	-	20	ns
E Pulse Width (High, Low)	t_w	230	-	-	ns
R/W and RS Setup Time	t_{su1}	40	-	-	ns
R/W and RS Hold Time	t_{h1}	10	-	-	ns
Data Setup Time	t_{su2}	80	-	-	ns
Data Hold Time	t_{h1}	10	-	-	ns

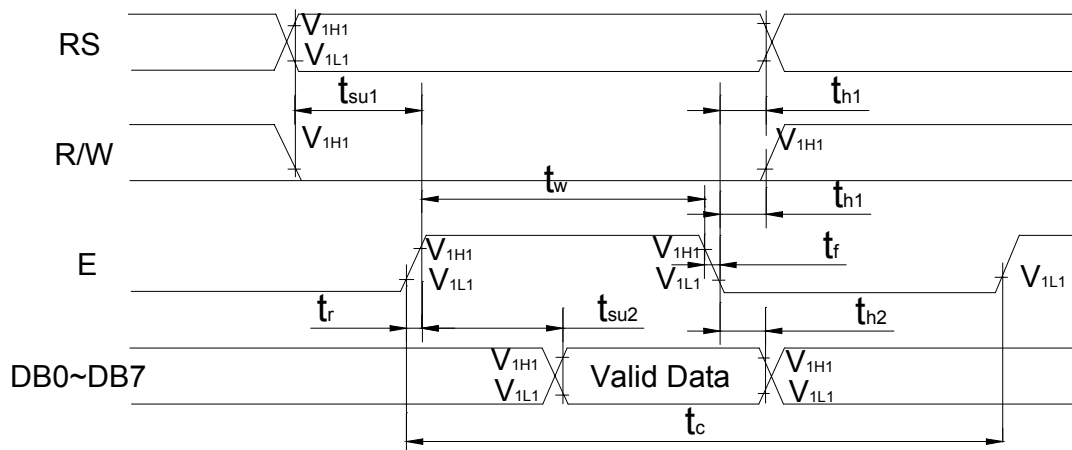

Write Mode Timing Diagram

7. TIMING CHARACTERISTICS (Continued)

7-2. Read Mode (Reading data from MPU to LCM)

Mode	Symbol	Min.	Typ.	Max.	Unit
E Cycle Time	t_c	500	-	-	ns
E Rise / Fall Time	t_r, t_f	-	-	20	ns
E Pulse Width (High, Low)	t_w	230	-	-	ns
R/W and RS Setup Time	t_{su1}	40	-	-	ns
R/W and RS Hold Time	t_{H1}	10	-	-	ns
Data Output Delay Time	t_{su2}	-	-	120	ns
Data Hold Time	t_{H1}	5	-	-	ns

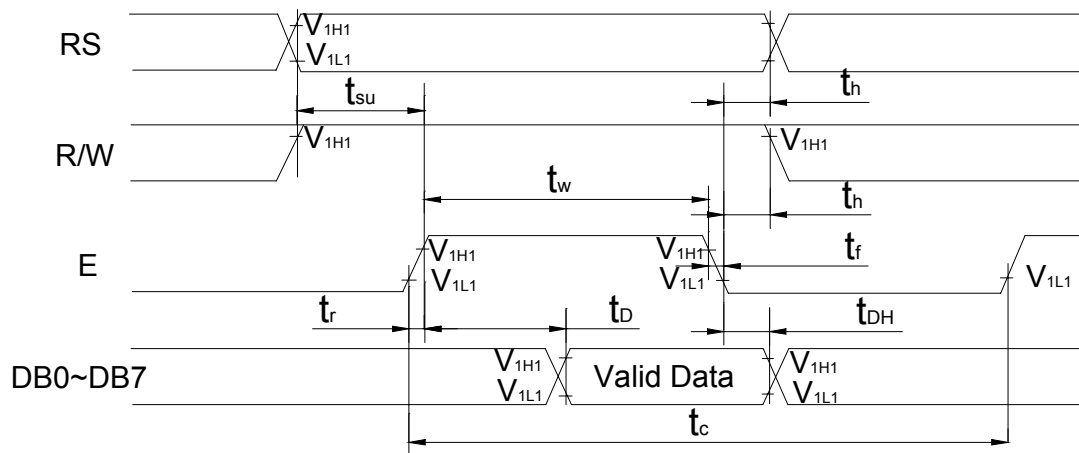

Read Mode Timing Diagram

8.INSTRUCTION SET

8-1. Instruction Table

Function	RS	R/W	DB 7	DB 6	DB 5	DB 4	DB 3	DB 2	DB 1	DB 0	Description	Execu. Time*(Max.)
Clear Display	0	0	0	0	0	0	0	0	0	1	Clear Entire Display	1.53mS
Return Home	0	0	0	0	0	0	0	0	1	*	Return Display Being Shifted to Original Position	1.53mS
Entry Mode Set	0	0	0	0	0	0	0	1	I/D	S	Set Cursor Move Direction And Specifies Shift of Display	39uS
Display ON/OFF Control	0	0	0	0	0	0	1	D	C	B	D: Display On /Off C: Cursor On/Off B: Cursor Blink/Not	39uS
Cursor or Display shift	0	0	0	0	0	1	S/C	R/L	*	*	Move Cursor And Shift Display	39uS
Function Set	0	0	0	0	1	DL	N	F	*	*	Set DL, N, F	39uS
Set CG RAM Address	0	0	0	1	ACG					Set CG RAM Address		39uS
Set DD RAM Address	0	0	1	ADD					Set DD RAM Address		39uS	
Read Busy Flag & Address	0	1	BF	AC					BF: Busy Flag Read AC Contents		0uS	
Write Data to CG RAM	1	0	WRITE DATA					Write Data to DD RAM or CG RAM		43uS		
Read Data From CG/DD RAM	1	1	READ DATA					Read Data From DD RAM or CG RAM		43uS		
Remark	I/D = 1 : Increment 0 : Decrement S = 1 : Accompanies Display Shift S/C = 1 : Display Shift 0 : Cursor Move R/L = 1 : Shift right 0 : Shift left DL = 1 : 8 Bits 0 : 4 Bits N = 1 : 2 Lines 0 : 1 Line F = 1 : 5 x 10 Dots 0 : 5 x 7 Dots BF = 1 : Internally Operating 0 : Can Accept Instruction										DD RAM : Display Data RAM CG RAM : Character Generator RAM ACG : CG RAM Address ADD : DD RAM Address Corresponds to Cursor Address AC : Address Counter used for Both DD and CG RAM Address * No effect (Don't care)	

NOTE: When an MPU program with checking the Busy Flag(DB7) is made, it must be necessary 1/2Fosc is necessary for executing the next instruction by the falling edge of the "E" signal after the Busy Flag(DB7) goes to "low".

8-2. DDRAM Address

Display position	Column	1	2	---	15	16
DD RAM Address (Hex-Decimal)	1-Line	00H	01H	---	0EH	0FH
	2-Line	40H	41H	---	4EH	4FH

MODEL

LMC1623A-YTDDYN-B0

9/21

PRODUCT SPECIFICATIONS

REV:A

8. INSTRUCTION SET (Continued)

8-3. Instruction Initialization

8-3-1. 8-bit interface mode

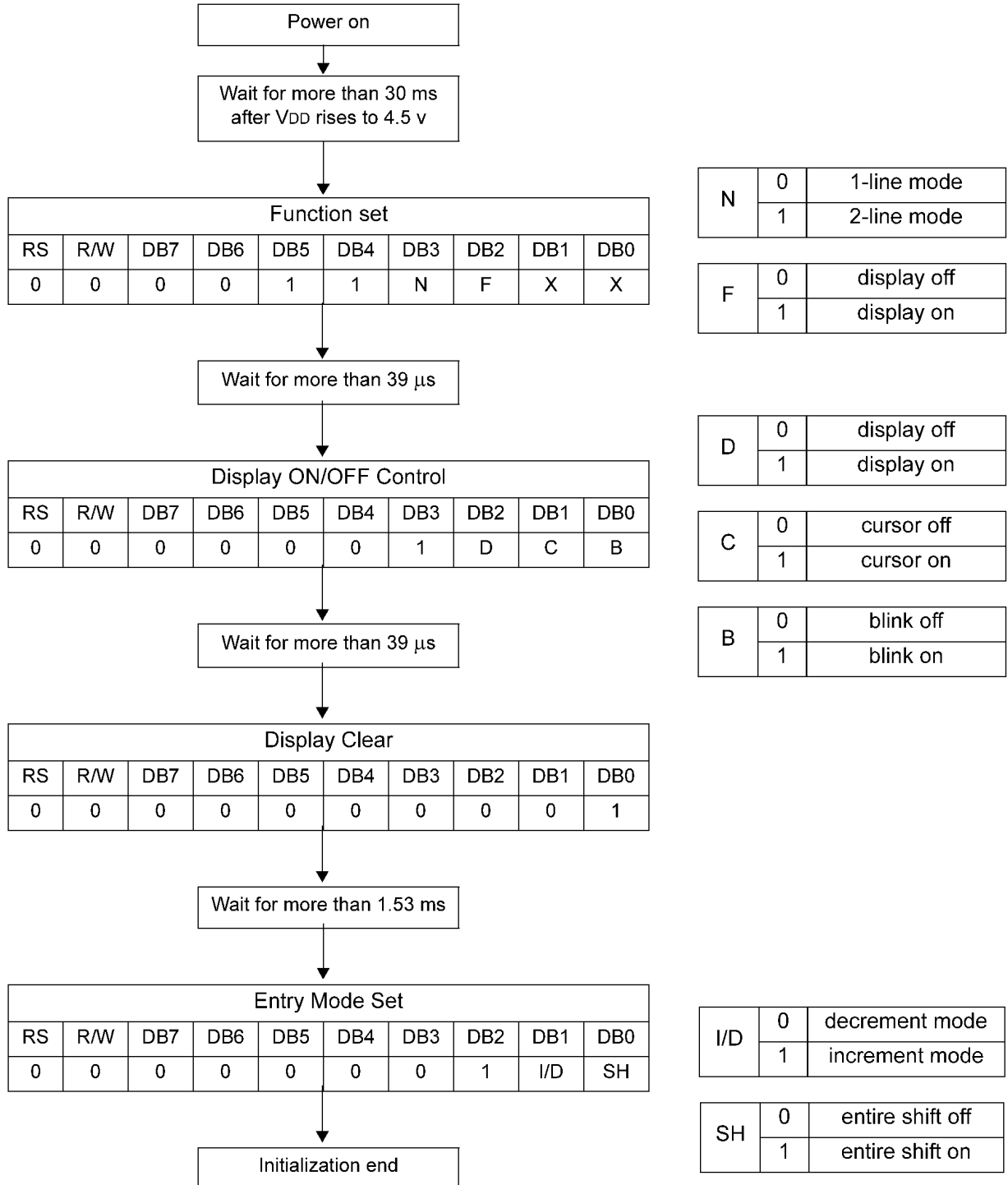

8. INSTRUCTION SET (Continued)

8-3. Instruction Initialization (Continued)

8-3-2. 4-bit interface mode

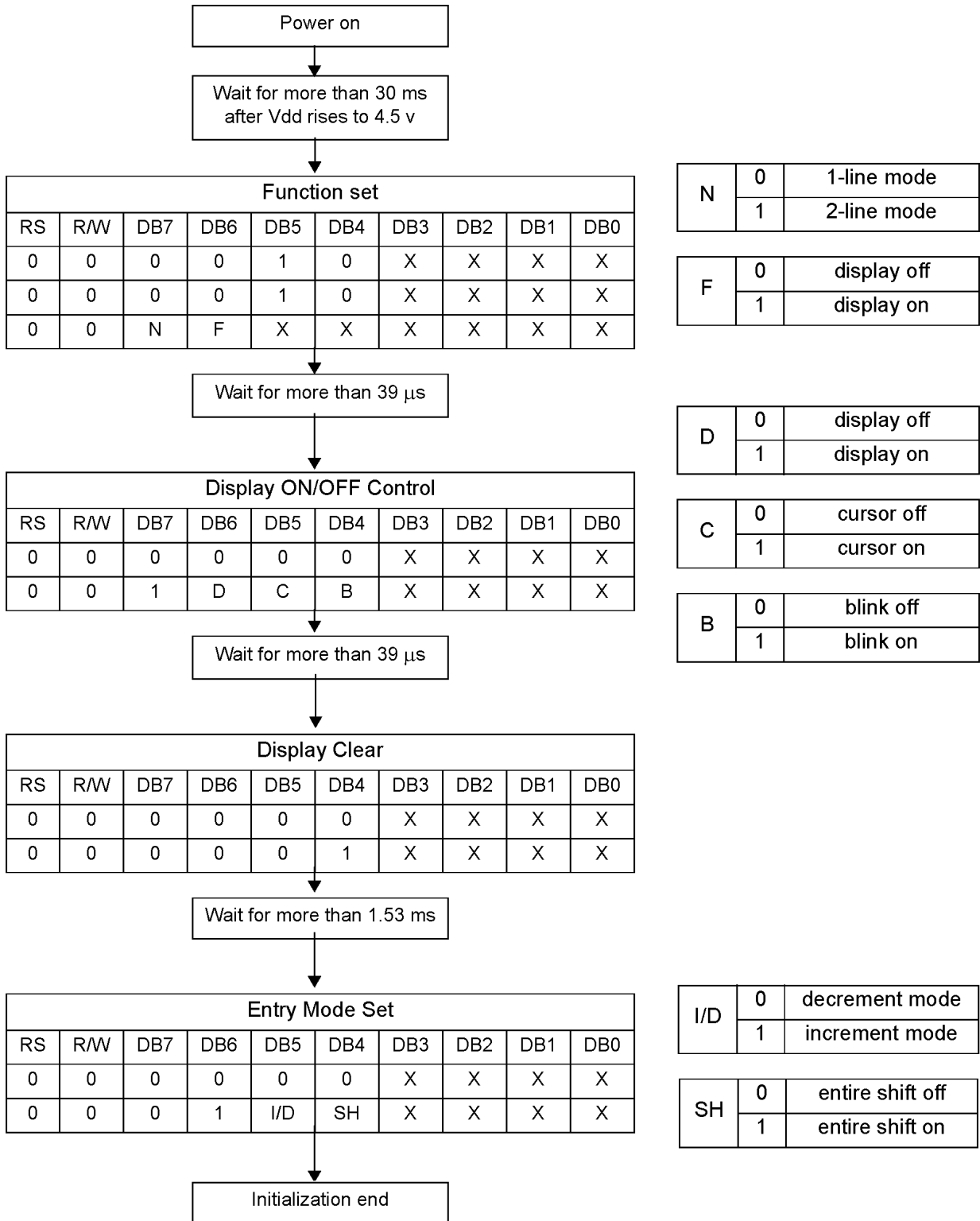

9. FONT TABLE

Upper 4 bit Lower 4 bit	LLLL	LLLH	LLHL	LLHH	LHLL	LHLH	LHHL	LHHH	HLLL	HLLH	HLHL	HLHH	HHLL	HHLH	HHHL	HHHH
LLLL				0	1	2	3	4				一	夕	三	×	尸
LLLH			!	1	A	Q	a	4			。	ア	チ	△	△	△
LLHL			"	2	B	R	b	r			「	イ	ウ	×	目	目
LLHH			#	3	C	S	c	s			」	ウ	子	毛	毛	毛
LHLL			\$	4	D	T	d	t			、	エ	ト	カ	目	目
LHLH			%	5	E	U	e	u			・	オ	大	工	区	目
LHHL			&	6	F	V	f	v			ヲ	カ	ニ	ヨ	目	目
LHHH			'	7	G	W	g	w			ヲ	キ	又	ラ	目	目
HLLL			(8	H	X	h	x			、	ウ	率	リ	目	目
HLLH)	9	I	Y	i	y			ウ	ウ	ル	目	目	目
HLHL			*	:	J	Z	j	z			エ	コ	目	目	目	目
HLHH			+	:	K	L	k	l			オ	オ	目	目	目	目
HHLL			,	<	L	1	l	1			カ	目	目	目	目	目
HHLH			-	=	M	I	m	i			ユ	又	目	目	目	目
HHHL			.	>	N	n	*	*			ヨ	セ	目	目	目	目
HHHH			/	?	O	O	*	*			ウ	ウ	目	目	目	目

10. QUALITY SPECIFICATIONS

10 - 1. LCM Appearance and Electric inspection Condition

1. Inspection will be done by placing LCM 30cm away from inspector's eyeballs under normal illumination.

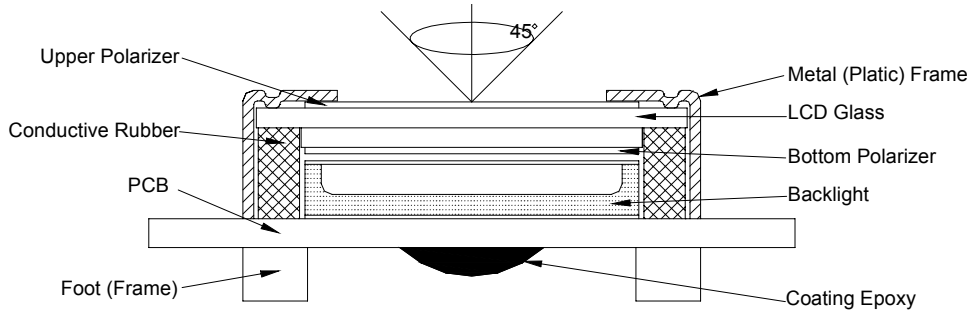

2. View Angle: with in 45° around perpendicular line.

10 - 2. Definition

1. COB

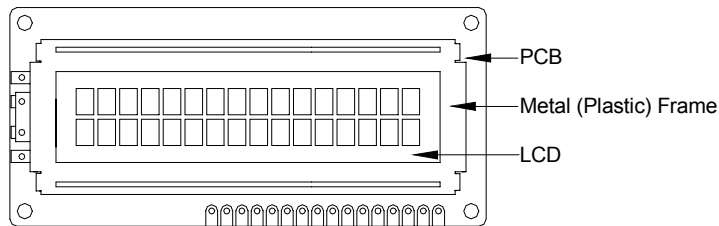

2. Heat Seal

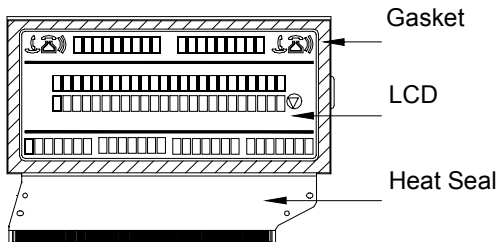

3. TAB and COG

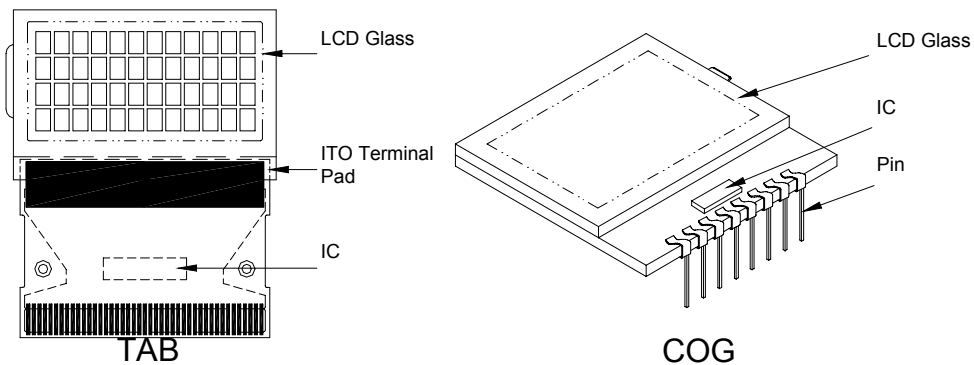

MODEL

LMC1623A-YTDDYN-B0

13/21

PRODUCT SPECIFICATIONS

REV:A

10. QUALITY SPECIFICATIONS (Continued)

10-3. Sampling Plan and Acceptance

1. Sampling Plan

MIL - STD - 105E (||) ordinary single inspection is used.

2. Acceptance

Major defect: AQL = 0.25%

Minor defect: AQL = 0.65%

10-4. Criteria

1. COB

Defect	Inspection Item	Inspection Standards	
Major	PCB copper flakes peeling off	Any copper flake in viewing Area should be greater than 1.0mm ²	Reject
Major	Height of coating epoxy	Exceed the dimension of drawing	Reject
Major	Void or hole of coating epoxy	Expose bonding wire or IC	Reject
Major	PCB cutting defect	Exceed the dimension of drawing	Reject

2. SMT

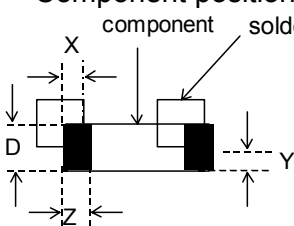
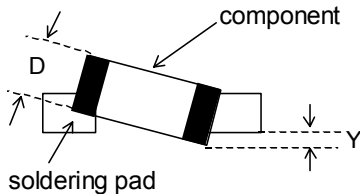
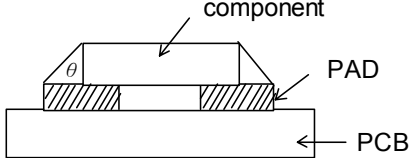
Defect	Inspection Item	Inspection Standards	
Minor	Component marking not readable		Reject
Minor	Component height	Exceed the dimension Of drawing	Reject
Major	Component solder defect (missing , extra, wrong component or wrong orientation)		Reject
Minor	<p>Component position shift</p> 	$X < 3/4Z$ $Y > 1/3D$	Reject Reject
Minor	<p>Component tilt</p> 	$Y > 1/3D$	Reject
Minor	<p>Insufficient solder</p> 	$\theta \leq 20^\circ$	Reject

MODEL

LMC1623A-YTDDYN-B0

14/21

PRODUCT SPECIFICATIONS

REV:A

10. QUALITY SECIFICATIONS (Continued)

10-4. Criteria (Continued)

3. Metal (Plastic) Frame

Defect	Inspection Item	Inspection Standards		
Major	Crack / breakage	Anywhere		Reject
Minor	Frame Scratch	W	L	Acceptable of Scratch
		$w < 0.1\text{mm}$	Any	Ignore
		$0.1 \leq w < 0.2\text{mm}$	$L \leq 5.0\text{mm}$	2
		$0.2 \leq w < 0.3\text{mm}$	$L \leq 3.0\text{mm}$	1
		$w \geq 0.3\text{mm}$	Any	0
		Note : 1. Above criteria applicable to scratch lines with distance greater than 5mm. 2. Scratch on the back side of frame (not visible) can be ignored .		
Minor	Frame Dent , Prick $\Phi = \frac{L + W}{2}$			Acceptable of Dents / Pricks
		$\Phi \leq 1.0\text{mm}$		2
		$1.0 < \Phi \leq 1.5\text{mm}$		1
		$1.5\text{mm} < \Phi$		0
		Note : 1. Above criteria applicable to any two dents / pricks with distance greater than 5mm 2. Dent / prick on the back side of frame (not visible) can be ignored		
Minor	Frame Deformation	Exceed the dimension of drawing		
Minor	Metal Frame Oxidation	Any rust		

4. Flexible Film Connector (FFC)

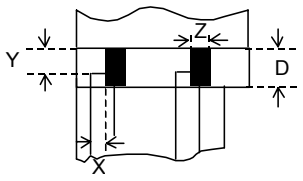
Defect	Inspection Item	Inspection Standards	
Minor	Tilted soldering	Within the angle $+5^\circ$	Acceptable
Minor	Uneven solder joint /bump		Reject
Minor	Hole $\Phi = \frac{L + W}{2}$	Expose the conductive line	Reject
		$\Phi > 1.0\text{mm}$	Reject
Minor	Position shift 	$Y > 1/3D$	Reject
		$X > 1/2Z$	Reject

MODEL

LMC1623A-YTDDYN-B0

15/21

PRODUCT SPECIFICATIONS

REV:A

10. QUALITY SPECIFICATIONS (Continued)

10-4. Criteria (Continued)

5. Screw

Defect	Inspection Item	Inspection Standards	
Major	Screw missing/loosen		Reject
Minor	Screw oxidation	Any rust	Reject
Minor	Screw deformation	Difficult to accept screw driver	Reject

6. Heatseal 、TCP 、FPC

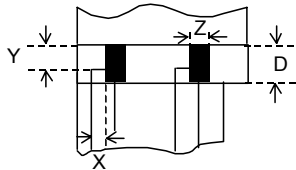
Defect	Inspection Item	Inspection Standards	
Major	Scratch expose conductive layer		Reject
Minor	HS Hole $\Phi = \frac{L+W}{2}$	$\Phi > 0.5\text{mm}$	Reject
Major	Adhesion strength	Less than the specification	Reject
Minor	Position shift 	$Y > 1/3D$	Reject
		$X > 1/2Z$	Reject
Major	Conductive line break		Reject

7. LED Backing Protective Film and Others

Defect	Inspection Item	Inspection Standards	
Minor	LED dirty, prick	Acceptable number of units	
		$\Phi \leq 0.10\text{mm}$	Ignore
		$0.10 < \Phi \leq 0.15\text{mm}$	2
		$0.15 < \Phi \leq 0.2\text{mm}$	1
		$\Phi > 0.2\text{mm}$	0
The distance between any two spots should be $\geq 5\text{mm}$ Any spot/dot/void outside of viewing area is acceptable			
Minor	Protective film tilt	Not fully cover LCD	Reject
Major	COG coating	Not fully cover ITO circuit	Reject

8. Electric Inspection

Defect	Inspection Item	Inspection Standards	
Major	Short		Reject
Major	Open		Reject

MODEL

LMC1623A-YTDDYN-B0

16/21

PRODUCT SPECIFICATIONS

REV:A

10. QUALITY SPECIFICATIONS (Continued)

10-4. Criteria (Continued)

9. Inspection Specification of LCD

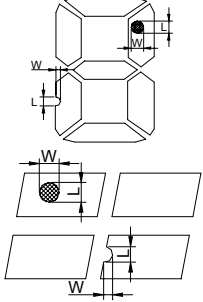
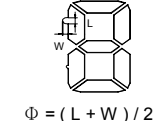
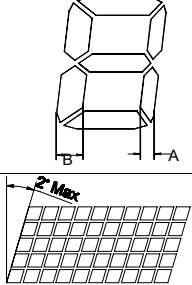
Defect	Inspect Item	Inspection Standards				
		W	W≤0.03	0.03<W≤0.05	W>0.05	
Minor	Linear Defect * Glass Scratch * Polarizer Scratch * Fiber and Linear material	L	L<5	L<3	Any	
		ACC. NO.	1	1	Reject	
		Note	L is the length and W is the width of the defect			
Minor	Black Spot and Polarizer Pricked * Foreign material between glass and polarizer or glass and glass * Polarizer hole or protuberance by external force	Φ	Φ≤0.1	0.1<Φ≤0.15	0.15<Φ≤0.2	Φ>0.2
		ACC. NO.	3EA / 100mm ²	2	1	0
		Note	Φ is the average diameter of the defect. Distance between two defects > 10mm.			
Minor	White Spot and Bubble in polarizer * Unobvious transparent foreign material between glass and glass or glass and polarizer * Air protuberance between polarizer and glass	Φ	Φ≤0.3	0.3<Φ≤0.5	0.5<Φ	
		ACC. NO.	3EA / 100mm ²	1	0	
		Note	Φ is the average diameter of the defect. Distance between two defects > 10mm.			
Minor	Segment Defect 	Φ	Φ≤0.10	0.10<Φ≤0.20	0.20<Φ≤0.25	Φ>0.25
		ACC. NO.	3EA / 100mm ²	2	1	0
		Note	W is more than 1/2 segment width Reject $\Phi = \frac{L + W}{2}$ Distance between two defect is 10mm			
Minor	Protuberant Segment 	Φ	Φ≤0.10	0.10<Φ≤0.20	0.20<Φ≤0.25	Φ>0.25
		W	Glue	W≤1/2 Seg W≤0.2	W≤1/2 Seg W≤0.2	Ignore
		ACC. NO.	3EA / 100mm ²	2	1	0
Minor	Assembly Mis-alignment 	1. Segment				
		B	B≤0.4mm	0.4<B≤1.0mm	B>1.0mm	
		B-A	B-A<1/2B	B-A<0.2	B-A<0.25	
		Judge	Acceptable	Acceptable	Acceptable	
		2. Dot Matrix				
	Deformation>2°			Reject		
Minor	Stain on LCD Panel Surface	Accept when stains can be wiped lightly with a soft cloth or a similar one. Otherwise, judged according to the above items: "Black spot" and "White Spot"				

MODEL

LMC1623A-YTDDYN-B0

17/21

PRODUCT SPECIFICATIONS

REV:A

11. RELIABILITY

NO.	Item	Condition	Criterion
1	High Temperature Operating	50°C, 240Hrs	No defect in cosmetic and operational function allowable.
2	Low Temperature Operating	0°C, 240Hrs	
3	High Humidity	40°C, 90%RH, 96Hrs	
4	High Temperature Storage	70°C, 240Hrs	
5	Low Temperature Storage	-20°C, 240Hrs	
6	Vibration	Random wave 10 ~ 100Hz Acceleration: 2g 2 Hrs per direction(X,Y,Z)	Total current Consumption should be below double of initial value.
7	Thermal Shock	0°C to 25°C to 50°C (60Min) (5Min) (60Min) 10Cycles	
8	ESD Testing	Contract Discharge Voltage: +1 ~ 5kV and -1 ~ -5kV Air Discharge Voltage: +1 ~ 8kV and -1 ~ -8kV	There will be discharged ten times at every discharging voltage cycle. The voltage gap is 1kV.

- Note:
- 1) Above conditions are suitable for GOLDENTEK standard products.
 - 2) For restrict products, the test conditions listed as above must be revised.

MODEL

LMC1623A-YTDDYN-B0

18/21

PRODUCT SPECIFICATIONS

REV:A

12. HANDLING PRECAUTIONS

(1) Mounting Method

The panel of the LCD Module consists of two thin glass plates with polarizers which easily get damaged since the Module is fixed by utilizing fitting holes in the printed circuit board. Extreme care should be taken when handling the LCD Modules.

(2) Caution of LCD handling & cleaning

When cleaning the display surface, use soft cloth with solvent (recommended below) and wipe lightly.

- Isopropyl alcohol
- Ethyl alcohol
- Trichlorotrifluoroethane

Do not wipe the display surface with dry or hard materials that will damage the polarizer surface.

Do not use the following solvent:

- Water
- Ketone
- Aromatics

(3) Caution against static charge

The LCD Module use C-MOS LSI drivers, so we recommend that you connect any unused input terminal to VDD or VSS, do not input any signals before power is turned on. And ground your body, Work/assembly table. And assembly equipment to protect against static electricity.

(4) Packaging

- Modules use LCD elements, and must be treated as such. Avoid intense shock and falls from a height.
- To prevent modules from degradation. Do not operate or store them exposed directly to sunshine or high temperature/humidity.

(5) Caution for operation

- It is indispensable to drive LCD's within the specified voltage limit since the higher voltage than the limit shorten LCD life. An electrochemical reaction due to direct current causes LCD deterioration, Avoid the use of direct current drive.

MODEL

LMC1623A-YTDDYN-B0

19/21

PRODUCT SPECIFICATIONS

REV:A

12. HANDLING PRECAUTIONS (Continued)

- Response time will be extremely delayed at lower temperature than the operating temperature range and on the other hand at higher temperature LCD's show dark color in them.

However those phenomena do not mean malfunction or out of order with LCD's. Which will come back in the specified operating temperature range.

- If the display area is pushed hard during operation, some font will be abnormally displayed but it resumes normal condition after turning off once.
- A slight dew depositing on terminals is a cause for electro-chemical reaction resulting in terminal open circuit.

Usage under the relative condition of 40°C, 50%RH or less is required.

(6) Storage

In the case of storing for a long period of time (for instance ,for years) for the purpose or replacement use, The following ways are recommended.

- Storage in a polyethylene bag with sealed so as not to enter fresh air outside in it, And with no desiccant.
- Placing in a dark place where neither exposure to direct sunlight nor light is. Keeping temperature in the specified storage temperature range.
- Storing with no touch on polarizer surface by the anything else. (It is recommended to store them as they have been contained in the inner container at the time of delivery)

(7) Safety

- It is recommendable to crash damaged or unnecessary LCD into pieces and wash off liquid crystal by using solvents such as acetone and ethanol.

Which should be burned up later.

- When any liquid crystal leaked out of a damaged glass cell comes in contact with your hands, please wash it off well with soap and water.

13. Outline Drawing

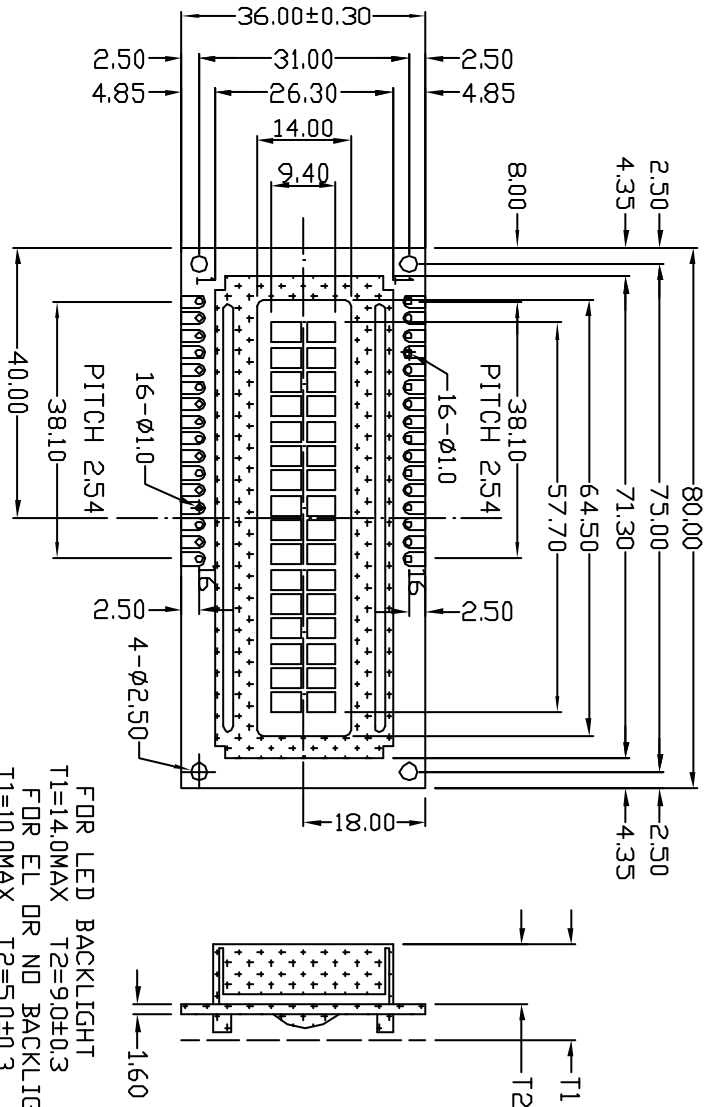

FOR LED BACKLIGHT
 T1=14.0MAX T2=9.0±0.3
 FOR EL DR NO BACKLIGHT
 T1=10.0MAX T2=5.0±0.3

1	2	3	4	5	6	7	8	9	10	11	12	13	14	15	16
VSS	VDD	V0	RS	R/W	E	DB0	DB1	DB2	DB3	DB4	DB5	DB6	DB7	A	K

- NOTES:
1. LCD TYPE: STN , YELLOWW-GREEN
 2. VIEWING ANGLE: 6:00 CLOCK
 3. POLARIZER: TRANSPARENTIVE/POSITIVE
 4. OPERATING TEMP: 0°C-50°C
 5. STORAGE TEMP: -20°C-70°C
 6. POWER SUPPLY: +5V, VLCD:4.6V
 7. BACKLIGHT:YELLOW-GREEN LED, +4.1V
 8. LCD DRIVE MODE: 1/16 DUTY, 1/5 BIAS
 9. LCD DRIVER: S6A0069 & S6A0065
 10. UNMARKED TOLERANCE: ±0.2mm

