

NO.	DESCRIPTION	PART NO.	QTY	MATERIAL	DRW NO.	REMARKS
1	INSULATOR		1	LCP		COLOR: BLACK
2	CONTACT		n	PHOS-BRONZE		AU PLATING

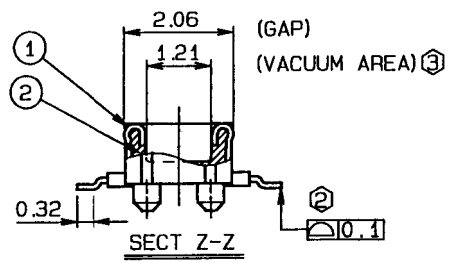

No. of POS.	A	B	C	D
16	2.8	4.3	5.3	3.7
20	3.6	5.1	6.1	4.5
24	4.4	5.9	6.9	5.3
30	5.6	7.1	8.1	6.5
32	6.0	7.5	8.5	6.9
34	6.4	7.9	8.9	7.3
36	6.8	8.3	9.3	7.7
40	7.6	9.1	10.1	8.5
50	9.6	11.1	12.1	10.5
54	10.4	11.9	12.9	11.3
60	11.6	13.1	14.1	12.5
70	13.6	15.1	16.1	14.5
80	15.6	17.1	18.1	16.5

\*生産対応可能な数量については、営業部に  
ご連絡願います。  
PLEASE ASK SALES DEPARTMENT  
WHAT NUMBER OF CONTACT CAN  
BE PRODUCED.

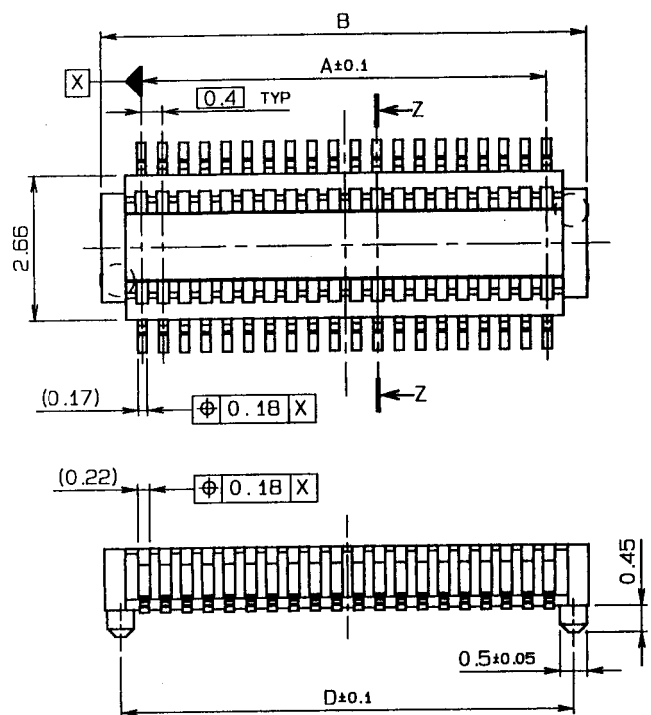
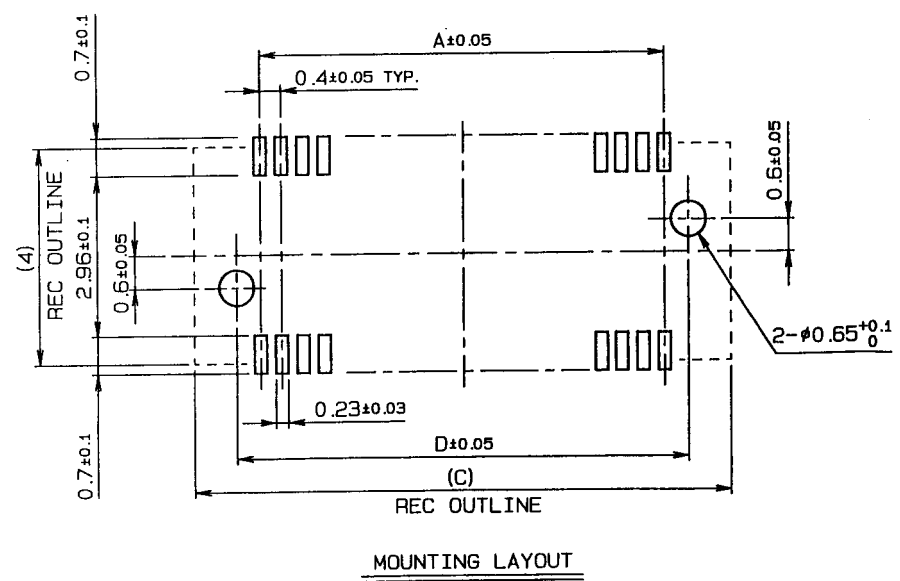
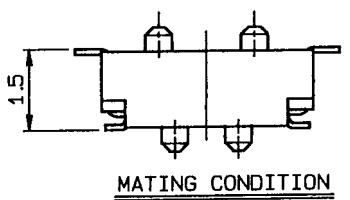
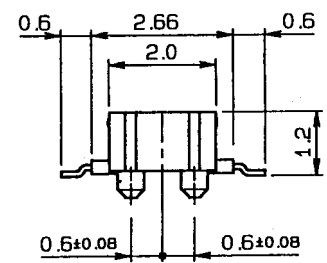

NOTE

1. 型番 P/N  
10 5602 XXX 00X 829  
管数  
NO. OF POS.  
VARIATION  
0: 金具無し、ボス無し  
WITHOUT ANCHOR PLATE AND BOSS  
1: 金具無し、ボス有り  
WITHOUT ANCHOR PLATE AND WITH BOSS
2. テール及び金具端面の相互の平行度は、0.1mm MAX.  
COPLANARITY OF CONTACT TAIL AND ANCHOR PLATE IS 0.1mm MAX.
3. 凸凹公差  
FLAT KEEPING AREA

技術部  
03.3.26  
発行

TOLERANCE / 公差 (S)		PRODUCT SPEC / 製品仕様		E DCN-293 3-20-03		Y. SHIROYAMA / T. ARAKI / M. HAYASHI	
X < 10	±0.2	D DCN-1456	10-03-02	M. YOSHIDA	Y. SHIROYAMA	T. SASAKI	
10 ≤ X < 30	±0.25	O EDN-710	11-02-01	Y. SHIROYAMA		N. HAYASHI	
30 ≤ X	±0.3	NO.	EDN/DCN	DATE	ISSUE	CHECKED	APPROVED
ANGLE / 角度	±3°	SCALE		DATE		PART NAME / 部品名	
		mm		11-02-01		SERIES 5602 PLUG ASSY ST SMT 0.4mm PITCH BOARD TO BOARD H=1.5mm	
DRAWN	DESIGNED	CHECKED	APPROVED	PART NO. / 部品番号			
Y. SHIROYAMA	Y. SHIROYAMA		N. HAYASHI	10 5602 XXX 00X 829			
KYOCERA ELCO CORPORATION				DWG NO. / 図番		SHEET REV	
				BJS 5602001		1/1 E	

NO.	DESCRIPTION	PART NO.	QTY	MATERIAL	DRW NO.	REMARKS
1	INSULATOR		1	HEAT RESISTING MATERIAL		COLOR: BLACK
2	CONTACT		n	PHOS-BRONZE		AU PLATING

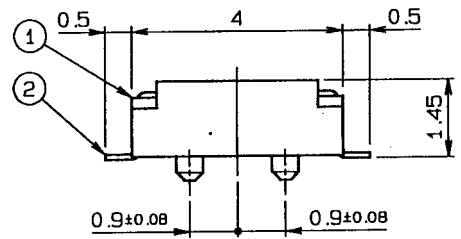
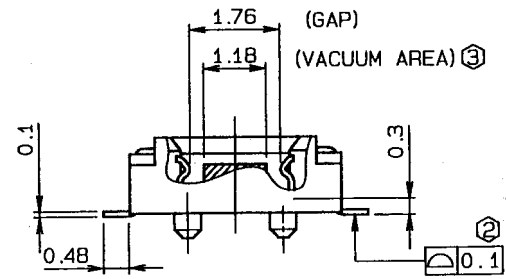
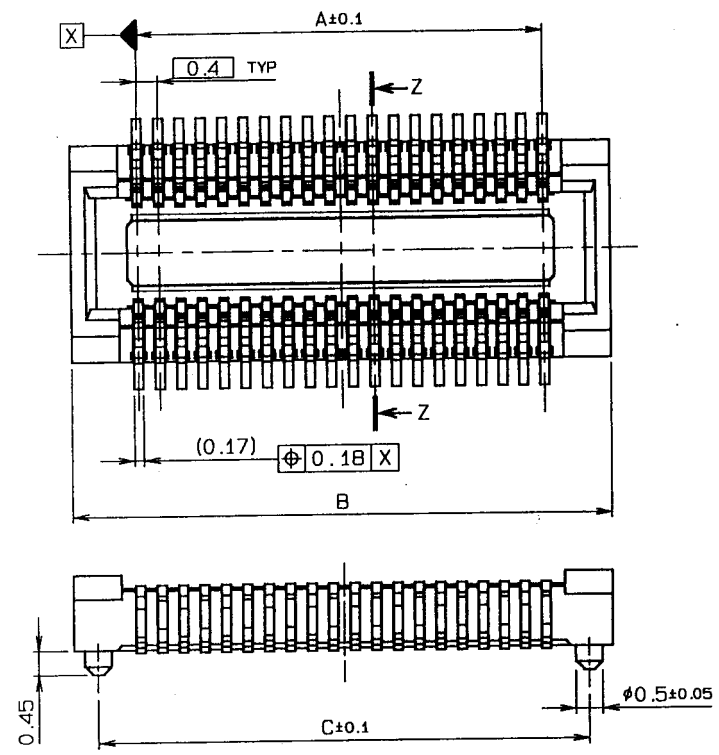

No. of POS.	A	B	C
16	2.8	5.3	4.4
20	3.6	6.1	5.2
24	4.4	6.9	6.0
30	5.6	8.1	7.2
32	6.0	8.5	7.7
34	6.4	8.9	8.0
40	7.6	10.1	9.2
50	9.6	12.1	11.2
54	10.4	12.9	12.0
60	11.6	14.1	13.2
70	13.6	16.1	15.2
80	15.6	18.1	17.2

NOTE  
 1. 型番 P/N  
 20 5602 XXX 00X 829  
 番 数  
 NO. OF POS.  
 VARIATION  
 0: 金具無し, ボス無し  
 WITHOUT ANCHOR PLATE AND BOSS  
 1: 金具無し, ボス有り  
 WITHOUT ANCHOR PLATE AND WITH BOSS  
 ② テール及び金具表面の相互の傾斜度は, 0.1mm MAX.  
 COPLANARITY OF CONTACT TAIL AND ANCHOR PLATE IS 0.1mm MAX.  
 ③ 凸凹残さ等  
 FLAT KEEPING AREA

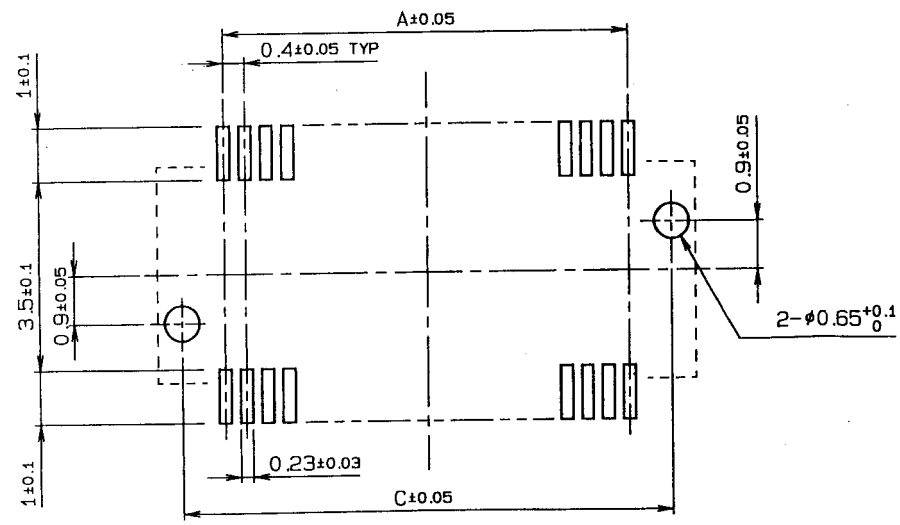

MOUNTING LAYOUT

技術部  
 0212.20  
 発行

TOLERANCE / 公差 (S)		PRODUCT SPEC / 製品規格		E	DCN-1754	12-11-02	Y. SHIROYAMA	T. SASAKI
10 ≤ X < 30	±0.2	UNIT	ANGLE	D	DCN-1456	10-03-02	M. YOSHIDA	Y. SHIROYAMA
30 ≤ X	±0.3	mm	3RD	O	EDN-710	11-02-01	Y. SHIROYAMA	N. HAYASHI
ANGLE / 角度	±3°	SCALE	DATE	PART NAME / 部品名				
		NYS	11-02-01	SERIES 5602 REC ASSY ST SMT				
DRAWN	DESIGNED	CHECKED	APPROVED	0.4mm PITCH BOARD TO BOARD H=1.5mm				
Y. SHIROYAMA	Y. SHIROYAMA		N. HAYASHI	PART NO. / 部品番号				
KYOCERA				20 5602 XXX 00X 829				
KYOCERA ELCO CORPORATION				DWG NO. / 図番				
				BJS 5602002				
				SHEET REV				
				1/1 E				