



PALM TECHNOLOGY CO., LTD.

The LCD(M) Specialist

CONTACT ADDRESS : 10F-1, No.392, Yu-Cheng Rd., Tso-Ying Dist.,
KHH, Taiwan, R.O.C.
Tel: 886-7-5587228
Fax: 886-7-5587229
E-mail: sales@palmtech.com.tw

PART NO. : PMG3224A2-SBF

FOR MESSRS. : _____

CONTENTS

NO.	ITEM	PAGE
1.	COVER	1
2.	RECORD OF REVISION	2
3.	GENERAL SPECIFICATION	3
4.	MECHANICAL DATA	3
5.	ABSOLUTE MAXIMUM RATINGS	4
6.	ELECTRICAL CHARACTERISTICS	5
7.	OPTICAL CHARACTERISTICS	5
8.	OUTLINE DIMENSION	6~7
9.	BLOCK DIAGRAM	7
10.	TIMING CHARACTERISTICS	8~9
11.	POWER SUPPLY FOR LCM	10
12.	PACKAGE DIAGRAM	11



ACCEPTED BY:

PROPOSED BY:

RECORD OF REVISION

DATE	PAGE	SUMMARY

3. General specifications

3.1 General specifications

PLEASE REFER TO:

“CUSTOMER ACCEPTANCE STANDARD SPECIFICATIONS (MS-10-10000)”.

3.2 Quality Assurance and Warranty

PLEASE REFER TO:

“QUALITY ASSURANCE MANUL (MS-10-10001)”.

3.3 This individual specification is prior to general specifications

4. Mechanical data

- (1) NUMBER OF DOTS----- 320 W * 240 H DOTS
- (2) MODULE SIZE ----- 167.5 W * 109.0 H * 13.0 T (max) mm
- (3) EFFECTIVE AREA ----- 120.5 W(min) * 92.0 H mm
- (4) ACTIVE AREA ----- 115.17 W * 86.37 H mm
- (5) DOT SIZE ----- 0.33 W * 0.33 H mm
- (6) DOT PITCH----- 0.36 W * 0.36 H mm
- (7) VIEWING DIRECTION ----- 6 O’CLOCK
- (8) LCD TYPE ----- STN.BLUE/NEGATIVE.TRANSMISSIVE
- (9) CCFL COLOR ----- WHITE

5. Absolute maximum ratings

5.1 Electrical absolute maximum ratings

<i>I T E M</i>	<i>SYMBOL</i>	<i>MIN.</i>	<i>MAX.</i>	<i>UNIT</i>	<i>COMMENT</i>
POWER SUPPLY FOR LOGIC	V _{DD} -V _{SS}	0	6.0	V	-----
INPUT VOLTAGE	V _I	V _{SS}	V _{DD}	V	-----
STATIC ELECTRICITY	-----	-----	100	V	NOTE (1)
POWER SUPPLY FOR CCFL BACKLIGHT	V _S	-----	AC1000	V _{rms}	-----
	f _{FL}	-----	55.0	KHz	-----
STARTING VOLTAGE FOR CCFL BACKLIGHT	V _{start1}	AC550	-----	V _{rms}	Ta = 25°C
	V _{start2}	AC700	-----	V _{rms}	Ta = 25°C
POWER SUPPLY FOR LCD	V _{DD} -V _{EE}	-----	30.0	V	-----

NOTE (1): ELECTRO-STATIC DISCHARGE RESISTANCE IS TESTED BY CHARGING A 200PF CAPACITOR AND DISCHARGING IT BY CONTACT WITH A INTERFACE CONNECTOR PIN.

5.2 Environmental absolute maximum ratings

<i>I T E M</i>	<i>OPERATING</i>		<i>STORAGE</i>		<i>COMMENT</i>
	<i>MIN.</i>	<i>MAX.</i>	<i>MIN.</i>	<i>MAX.</i>	
AMBIENT TEMPERATURE	-20°C	70°C	-20°C	70°C	-----
HUMIDITY	NOTE (2)		NOTE (2)		NO CONDENSATION
VIBRATION NOTE (3)	-----	0.5G	-----	2G	10~300Hz XYZ DIRECTIONS 1 Hr EACH
SHOCK NOTE (3)	-----	3G	-----	50G	10 msec XYZ DIRECTIONS 1 TIME EACH
CORROSIVE GAS	NOT ACCEPTABLE		NOT ACCEPTABLE		-----

NOTE (2): Ta ≤ 70°C: 75% RH MAX.

Ta > 70°C: ABSOLUTE HUMIDITY MUST BE LOWER THAN THE HUMIDITY OF 75% RH AT 70°C.

NOTE (3): 1G = 9.8 m/s²

6. Electrical characteristics

Ta = 25°C VDD = 5.060.25 V

<i>I T E M</i>	<i>SYMBOL</i>	<i>CONDITION</i>	<i>MIN.</i>	<i>TYP.</i>	<i>MAX.</i>	<i>UNIT</i>
Power supply voltage for circuit	VDD-VSS	-----	4.75	5.0	5.25	V
Power supply voltage for LCD drive	VEE-VSS	-----	-21.0	-22.0	-22.5	V
Input voltage, NOTE (1)	V _{IH}	H LEVEL	0.8V _{DD}	-----	V _{DD}	V
	V _{IL}	L LEVEL	V _{SS}	-----	0.2V _{DD}	V
Power supply current, NOTE (2)	I _{DD}	V _{DD} -V _{SS} = 5.0V	-----	5.5	7.5	mA
LCD display duty ratio	DUTY	-----	-----	1/240	-----	-----
Recommended LCD driving voltage, NOTE (3)	V _{DD} -V _O Φ = 10° θ = 0°	Ta = 70°C	-----	21.6	-----	V
		Ta = 25°C	-----	23.5	-----	V
		Ta = -20°C	-----	25.0	-----	V
CCFL LAMP	V _{FL}	f _{FL} = 35KHz	-----	270	-----	V _{rms}
	I _{FL}	V _{FL} = 270 V _{rms} f _{FL} = 35 KHz	-----	5.0	-----	mArms
CCFL Lifetime	-----	V _{FL} =270V _{rms} f _{FL} =35KHZ	-----	40,000	-----	Hr
Power supply LCD current	I _{EE}	V _{DD} -V _O =23.5V	-----	5.0	7.0	mA
FLM frequency	F _{FLM}	-----	70	75	80	Hz

NOTE (1): APPLIED TO TERMINALS D0~D3, LOAD, CP, $\overline{\text{DISP OFF}}$

NOTE (2): THE DISPLAY PATTERN IS ALL "ON", OR ALL "OFF"

NOTE (3): RECOMMENDED LCD DIRVING VOLTGE MAY FLUCTUATE ABOUT60.5V BY EACH MODULE.

7. Optical characteristics

Ta = 25°C VDD-V_O = 23.5V

<i>I T E M</i>	<i>SYMBOL</i>	<i>CONDITION</i>	<i>MIN.</i>	<i>TYP.</i>	<i>MAX.</i>	<i>UNIT</i>	<i>NOTE</i>
Viewing angle	Φ2-Φ1	K ≥ 2.0	40	50	-----	Deg.	1
Contrast ratio	K	Φ = 10° θ = 0°	5.0	6.0	-----	-----	1
Response time (at 25°C)	tr (rise)	Φ = 10° θ = 0°	-----	215	-----	ms	1
	tf (fall)	Φ = 10° θ = 0°	-----	150	-----	ms	1
The brightness of backlighting source	B	DOTS ALL ON V _{FL} =260V _{rms} f _{FL} =35KHZ	-----	60	-----	cd/m ²	2

NOTE (1): SEE CUSTOMER ACCEPTANCE STANDARD SPECIFICATION FOR DEFINITION OF OPTICAL CHARACTERISTICS

NOTE (2): UNDER NORMAL TEMPERATURE AND HUMIDITY IN A DARK ROOM

8. Outline dimension

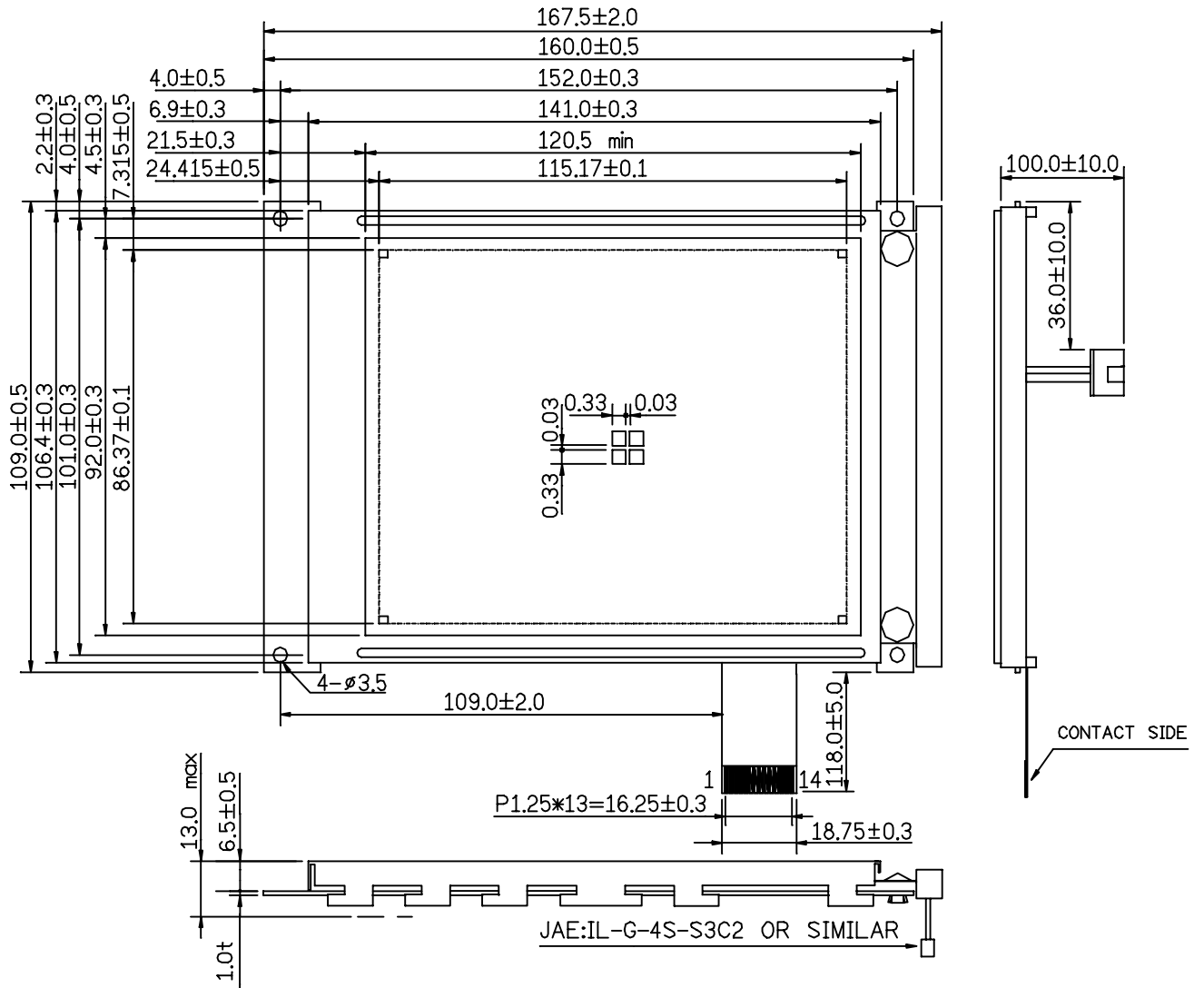

UNIT:mm

SCALE:NTS

NOT SPECIFIED OLERANCE: ± 0.01

8.1 Interface

(a) Pin Assignment

PIN NO.	SYMBOL	FUNCTION
1	D0	DISPLAY DATA
2	D1	DISPLAY DATA
3	D2	DISPLAY DATA
4	D3	DISPLAY DATA
5	$\overline{\text{DISPOFF}}$	L: DISPLAY OFF H: DISPLAY ON
6	FLM	FRAME PULSE
7	N.C	NO CONNECTION
8	LOAD	DATA LATCH PULSE
9	CP	DATA SHIFT CLOCK PULSE
10	V _{DD}	POWER SUPPLY FOR LOGIC
11	V _{SS}	GRAND
12	V _{EE}	POWER SUPPLY FOR LCD
13	V _O	LCD DRIVING VOLTAGE
14	F.G	FRAME GRAND

(b) CCFL Connector

PIN NO.	SYMBOL	FUNCTION
1	V _{CCFL}	POWER SUPPLY VOLTAGE FOR CCFL
2	N.C	NO CONNECTED
3	N.C	NO CONNECTED
4	V _{CCFL}	POWER SUPPLY VOLTAGE FOR CCFL

9. Block diagram

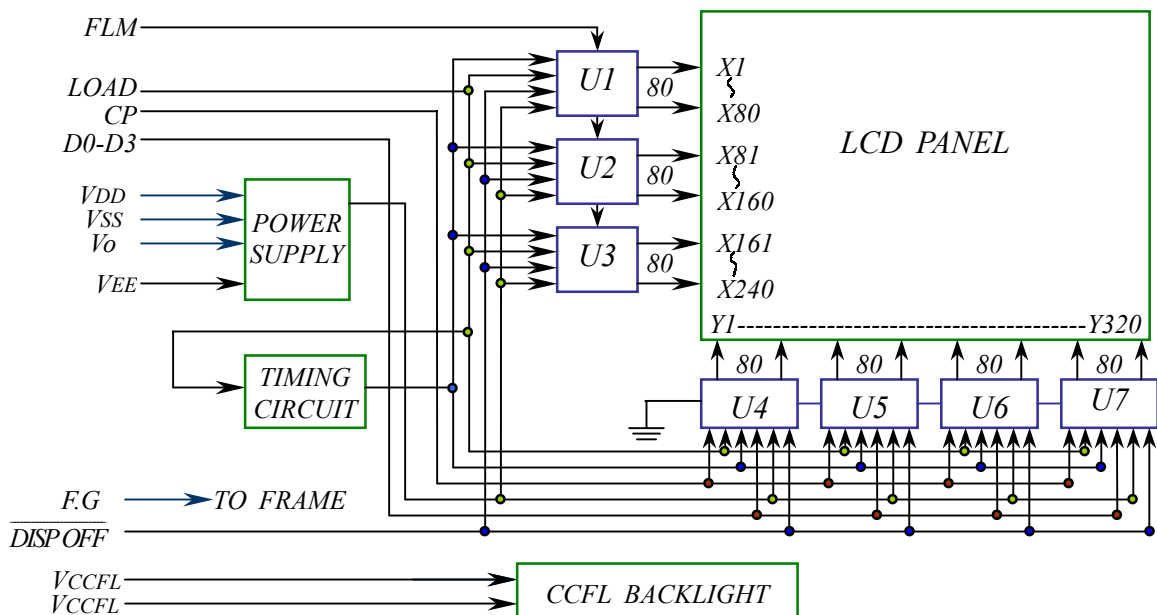

10. Timing characteristic

ITEM	SYMBOL	MIN	MAX	UNIT
LOAD PULSE WIDTH "H"	t_{WHCL1}	50	-----	ns
CP PULSE WIDTH	t_{HCL2}	50	-----	ns
CLOCK SET UP TIME	t_{SCL1}	80	-----	ns
CLOCK HOLD TIME	t_{HCL1}	80	-----	ns
CLOCK RISE/FALL TIME	$t_{r/f}$	-----	50	ns
DATA SET UP TIME	t_{DSU}	30	-----	ns
DATA HOLD TIME	t_{DH}	30	-----	ns
FLM DATA SET UP TIME	t_{FS}	100	-----	ns
FLM DATA HOLD TIME	t_{FH}	100	-----	ns
CLOCK CYCLE TIME	t_{CYC}	125	-----	ns

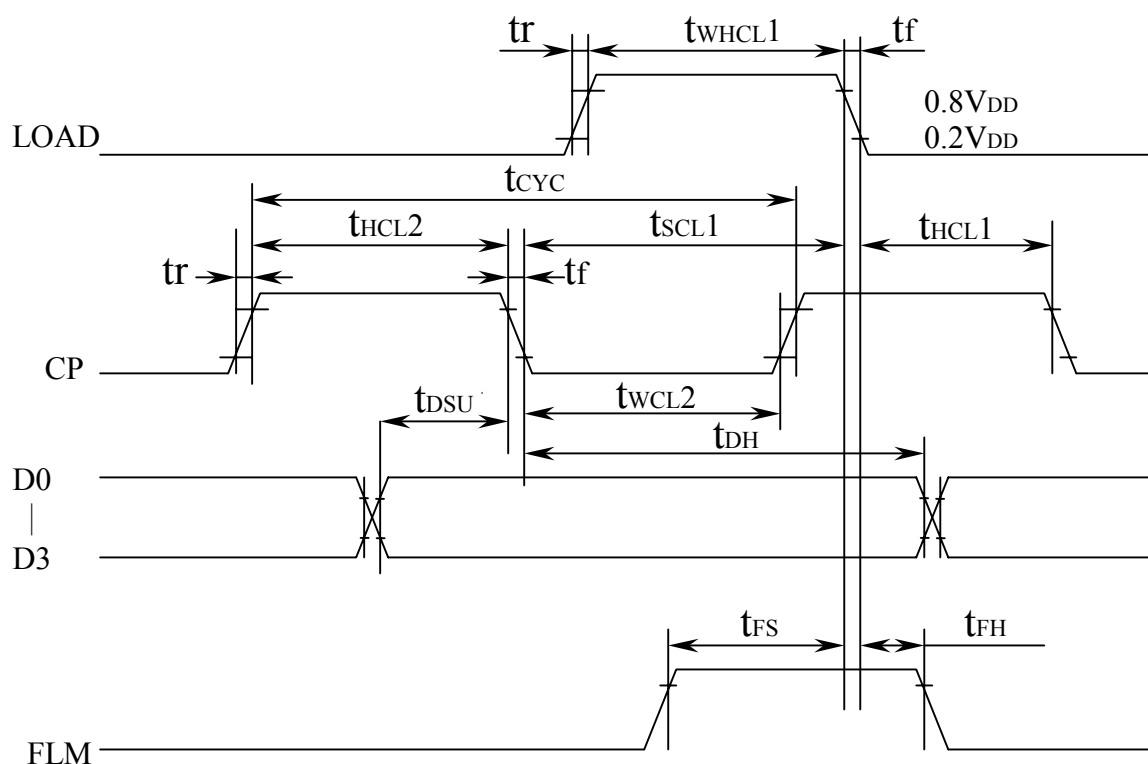

10.1 Interface timing chart

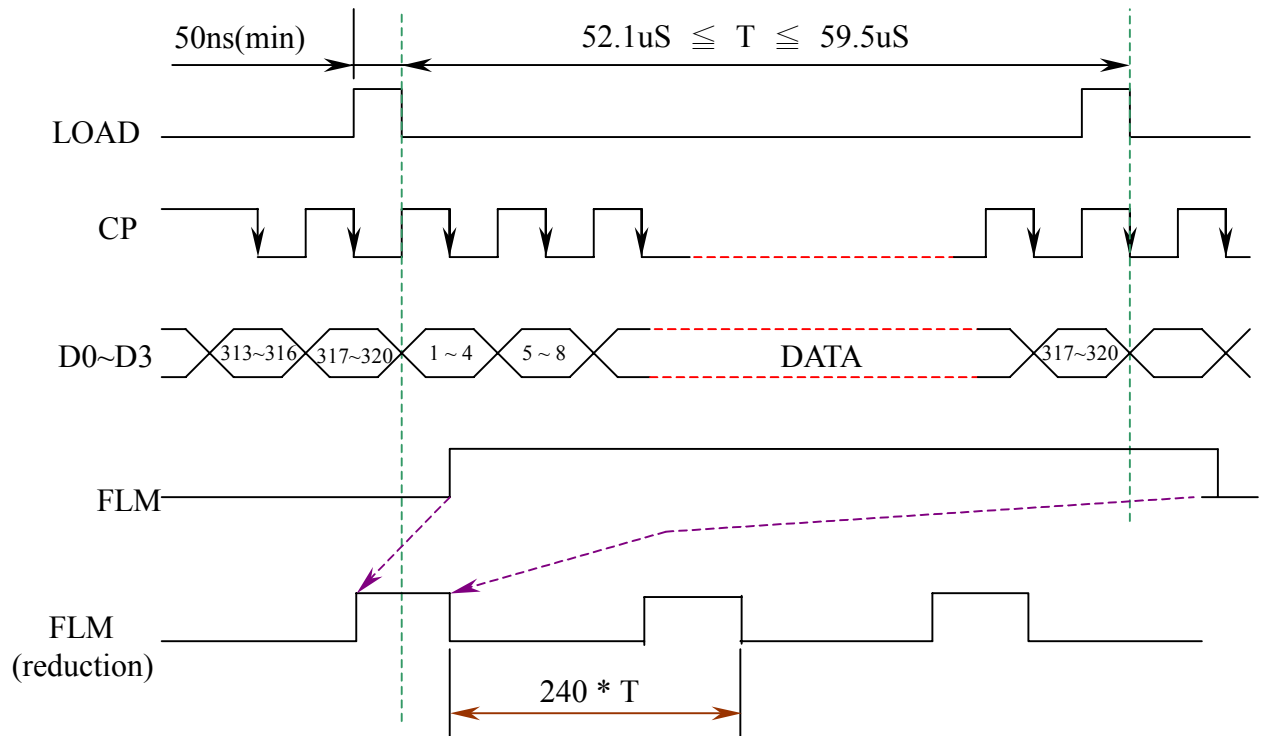

10.2 Comparison between display and data

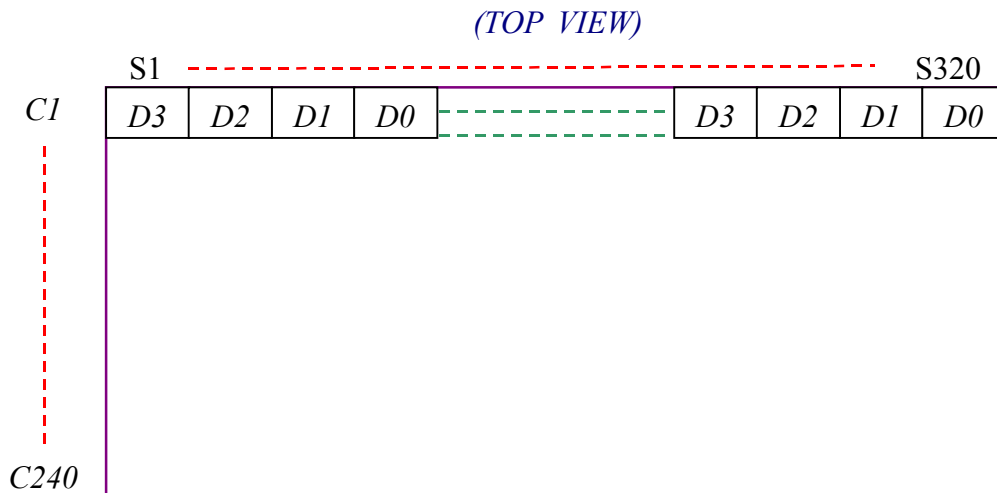

11. Power supply for LCM

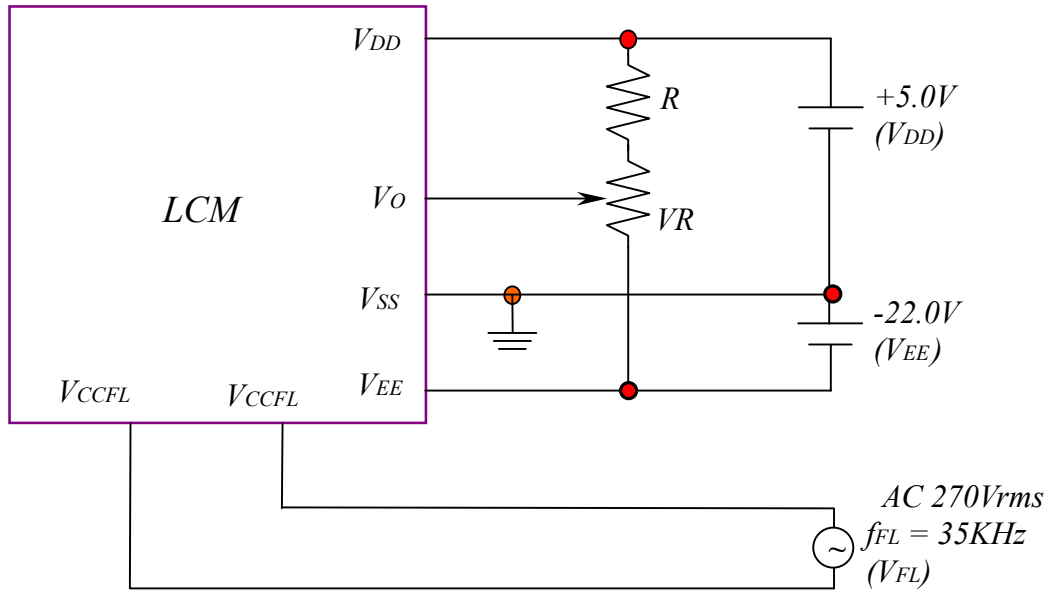

$V_{DD}-V_O$: LCD DRIVING VOLTAGE
 RECOMMEND RESISTOR R: $V_{DD}-V_O \geq 1.5V$
 VR: 200K Ω

Power supply sequency

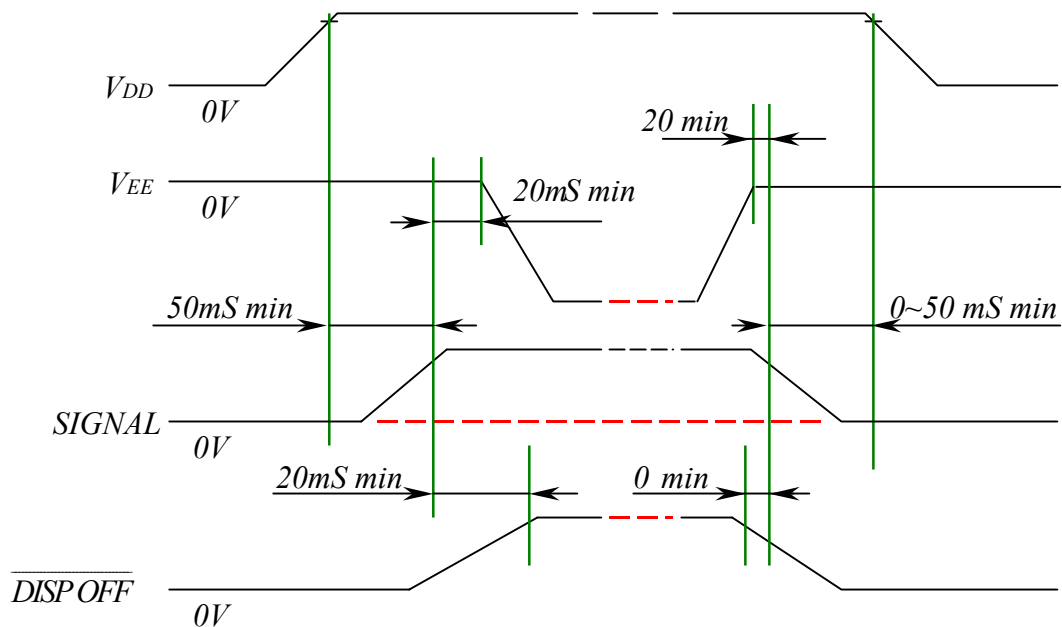

12. PACKAGE DIAGRAM

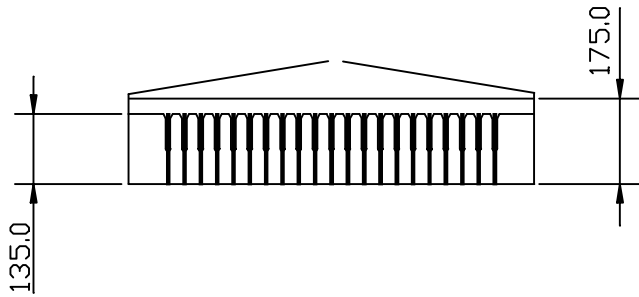
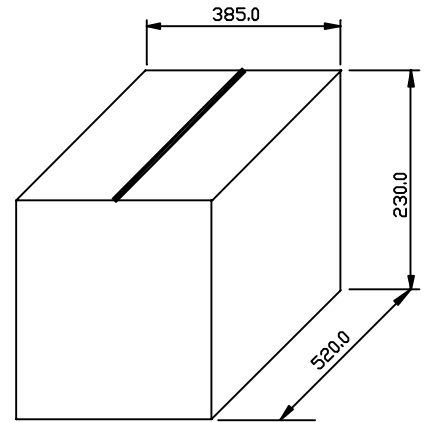
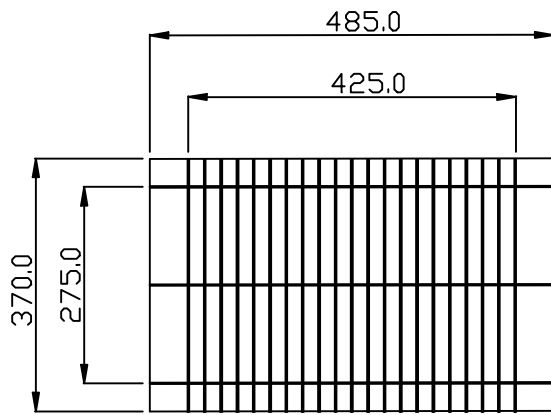

NOTE:

- a. $t=5.0$
- b. Inside package : 40PCS
- c. Outside package :
inside package*1 = 40PCS
- d. Total weight : 11.0kg

↙ Outside package



↗ Inside package